

**KARDANAN SHARGH CO.**

Oil - Gas - Petrochemical



**kardanan shargh co.**  
Control System & Instruments

**Head Office:** Unit 9 - No 152, Sheikh Bahai Sq,  
North Sheikh Bahai St, Tehran, IRAN  
Tel: +98 21 88621764 - 88622037  
Fax: +98 21 88621801

**Factory:** No.201B, 6th Andisheh, 2nd Phase,  
Toos ind. Estate, Mashhad, IRAN  
Tel: +98 51 35413810-12  
Fax: +98 51 35416383

[www.kardananeshargh.com](http://www.kardananeshargh.com)

Since 1995

## Company History

In 1995 Kardanan Shargh was established. The charter of KS was to design and manufacture Wellhead Safety Control Systems for local market, specifically for the Northern East of IRAN.

KS collected all knowledge about design and manufacturing requirements for Safety Control Systems for 5 years and finally success to localize it as the first Iranian manufacturer.

In 2000 KS supplied the first safety ATEX certified safety system PLC operated for KHANGIRAN gas filed (the Northern East of IRAN) and 2 years later manufactured the first chemical injection package for TABNAK gas filed (South of IRAN).

Today, KS has many sign in every part of operational areas in IRAN.

As a first Iranian company, KS has designed and manufactured first localized Multi WHCP for offshore platform which complied all the requirements of customers and related standards. Furthermore the PLC base WHCPs which were designed for SARVAK AZAR oil field, were SIL 3 certified for the first time in Iran by one of the most recognized and well-known SIL assessment European company.

For further information about our references, please refer to the next page.

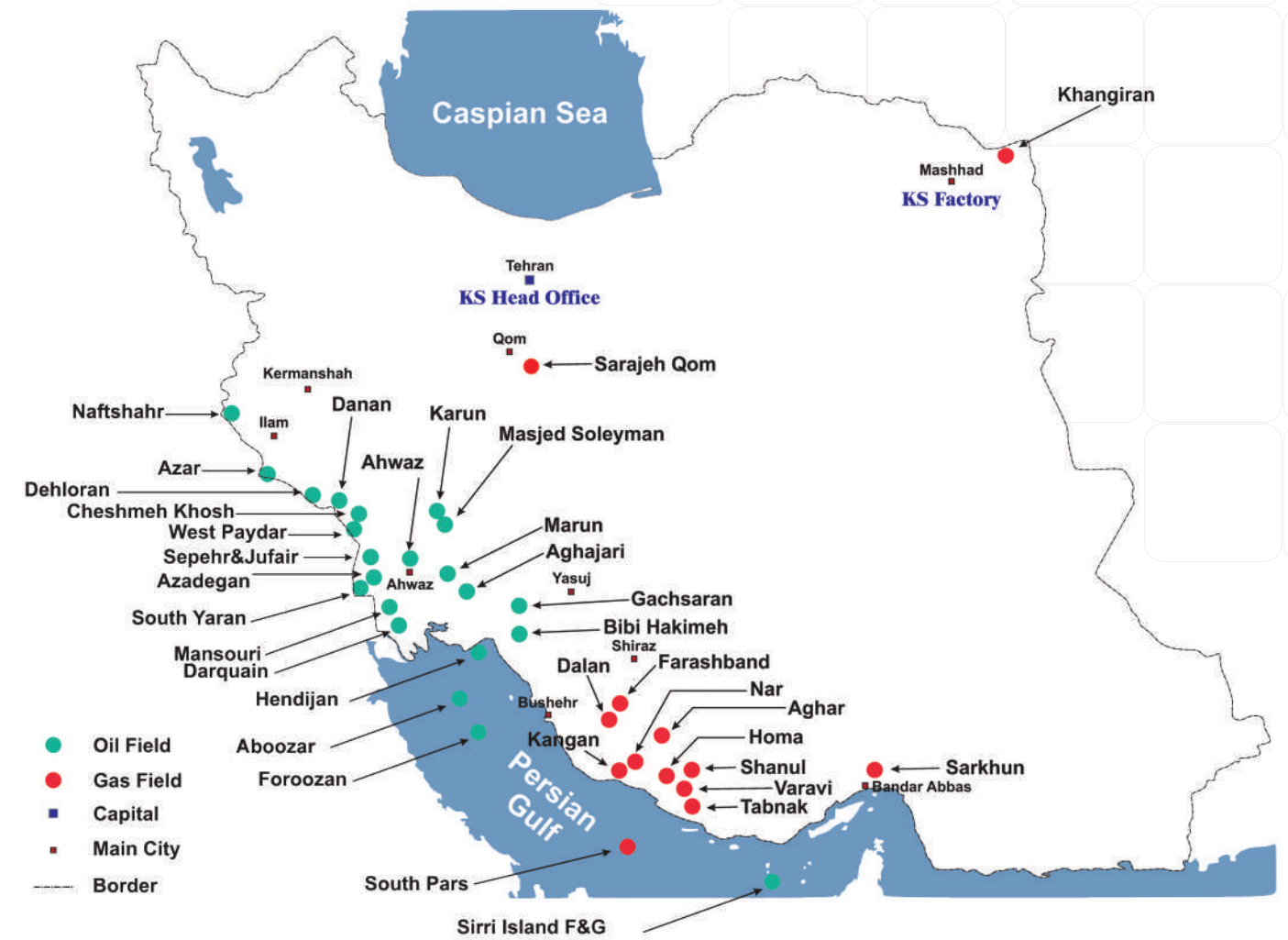

## CONTENTS

■ Abilities	-----	3-4
■ Multi Wellhead Control Panel	-----	5-6
■ Single Wellhead Control Panel(Electro-Hydraulic)	-----	7-8
■ Single Wellhead Control Panel(Air/Gas Drive)	-----	9-10
■ Adjustable Pilot Valve	-----	11-12
■ PLC Control System	-----	15-16
■ Chemical Injection Package	-----	17-18
■ Actuator & Control Panel	-----	19-20
■ HIPPS-ESDV	-----	21
■ Hydraulic Power Unit (HPU) & Power Handwheel	-----	22
■ Flare & Burn Pit Ignition Panel	-----	23-24
■ Supplier & Agent	-----	25
■ ISO Certificates	-----	26

### Abilities

We design and supply equipment for the international oil and gas industry. What we do is important. But how we do it makes the real difference.

Whether you are searching for onshore and offshore solutions, our teams will meet your demands. At KS, we combine decades of extensive experience in providing high-end hydraulic systems for the upstream oil and gas industry with state-of-the-art technology to create innovative systems and solutions, solving all challenges presented to us by our clients.

We have been providing tailor-made solutions since 1995, and our systems ensure safe control of processes at oil and gas plants operated by corporate end-users located worldwide. From concept through to design, production, testing and delivery, we will use the latest technology to precisely meet your needs.

We are solution-oriented and we understand your industry.

Thanks to our global office and service network, international supply chain, and partnerships with leading vendors, we are able to supply the best systems to precisely meet all your requirements.



### Engineering & Design

Our engineering team is constantly innovating to increase the value of our customer assets across the whole range of production conditions. Whether you require on entirely new system or the modification of an existed one, our team works closely with the production department to maximize functionality and reliability.

### Manufacturing

Whether your needs are mechanical or electrical KS facility and equipment offer the capability to handle projects of all sizes. Our unique manufacturing capabilities include:

- Tubing & Piping
- Cabling & Wiring
- Sheet Metal Fabricating
- Welding
- Surface Preparation
- Painting

### Supply & Procurement

We procure and stock the required maintenance spares ensuring timely delivery of spare kits necessary for each planning maintenance routine of our customers of our customers and also minimizing their stock holding and costs. We also have the ability to supply necessary spare parts to Iran oil & gas industries based on KS agency agreement with some of reputable international manufacturer in Asia and Europe.

### Technical Support

- Technical Consultation
- Training: We have special training courses compatible to project for our end users. Since the theoretical and practical knowledge are the bases for a safe operation training courses for customers are one of the most important services which are also provided by our Technical & Engineering department
- Repair contracting
- After sales services



## Multi Wellhead Control Panel (MWHCP)

This Wellhead control panel usually use for offshore oil/gas fields; these units are designed as removable drawer module type and generally comprises of supply and DHSV return reservoirs, electrically driven hydraulic pumps, accumulators, pressure regulators, hand pumps, filters and associated control and instrumentation for both, the LP hydraulic supply headers and the HP hydraulic supply headers.

The Wellhead Control Panel is designed as a fully enclosed assembly with the Hydraulic Power Unit providing a common source of hydraulic power for each well control module. The simplicity or complexity of the systems is purely down to the clients request based on the requirements of the project.

Also PLC control systems can be considered as Instrumented Protective System (IPS) for Wellhead valves Open/Close sequence, Control, Operation and shutdown safety requirements & to meet high degree of Reliability, Availability, Functional safety and complete integrity.

These type of Wellhead Control Panels are designed for controlling the Down Hole Safety Valves (DHSV) Master Valves (MV), Wing Valves (WV), Choke Valves and Gas Lift Valves. The logic signal for controlling the system is hydraulic or pneumatic.



## Key Features

- API RP 14C & API RP 14B
- SIL-3 (PLC Base), Eex 'd', NEMA-4X, IP65 Certified Panels
- NACE MR0175/ ISO-15156 Compliant Panels
- Hydraulic/Pneumatic Fusible Plug Loop
- ASME, PED 97/23/EC Design Compliant Components
- Cleanliness Level to any NAS, ISO, SAE Level
- Protective Coating for Harsh Environmental Conditions
- High Pressure High Temperature (HPHT) Panels
- Arctic Service Panels
- 3D Model Design Review
- Reliability and Availability Study
- SS316L and Inconel/904L Tubing Material

## Additional Services

- Installation / Training
- Start-Up Supervision
- Extended Warranty
- Customized Design

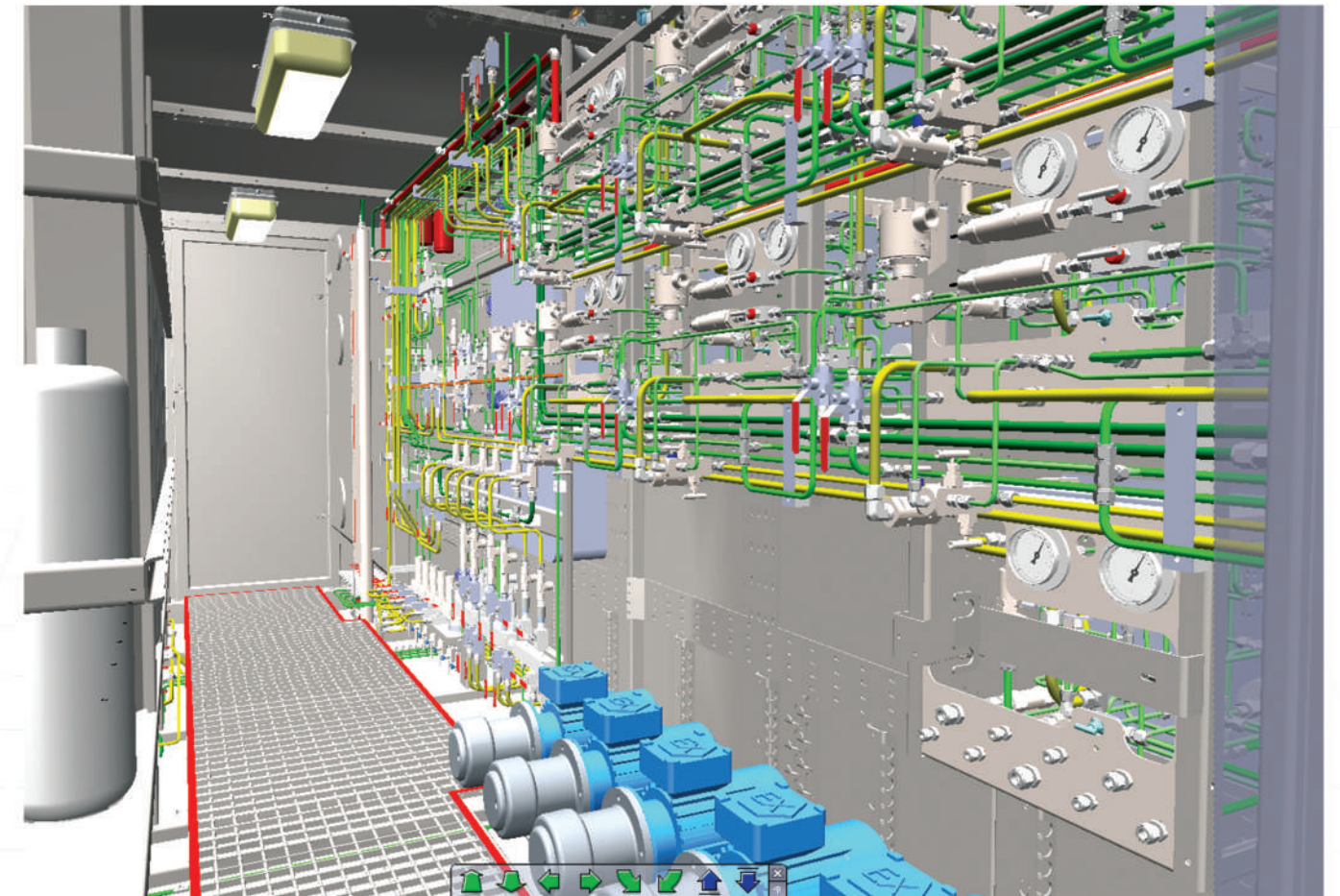

## WHCPs may have multiple applications, which include, but are not limited to:

- Safe and Sequential Operation of Wellhead Valves (DHSV/SSV/WV Etc.)
- Emergency and Fire Shutdown
- Safe Operation of Riser Valves
- Flow line Pressure Control
- Well Test Operation
- HIPPS /ESD/ Choke Valve Control

## Single Wellhead Control Panel (Electro-Hydraulic)

This Wellhead Control Panel designed to control single well; the unit usually integrated fixed assembly but it can be designed as removable drawer module type.

It generally comprises of supply and SSSV return reservoirs, electrically driven hydraulic pumps, accumulators, pressure regulators, hand pump, filters and associated control and instrumentation for both, the LP hydraulic supply headers and the HP hydraulic supply headers. In this type of WHCP, LOW and HIGH pressure of pipeline are sensed by electrical pressure switches.

The Wellhead Control Panel is designed as a fully enclosed assembly with the Hydraulic Power Unit providing a common source of hydraulic power for each well control module.

The simplicity or complexity of the systems is purely down to the clients request based on the requirements of the project.

These type of Wellhead Control Panels are designed for controlling the Sub-Surface Safety Valves (SSSV), Surface Safety Valves (SSV), Wing Valves (WV) and Supply the hydraulic pressure for HIPPS and ESD Valves. The logic signal for controlling the system is hydraulic.



## WHCPs may have multiple applications, which include, but are not limited to:

- Safe and Sequential Operation of Wellhead Valves (SSSV/SSV/WV Etc.)
- Emergency and Fire Shutdown
- Flow line Pressure control
- Well Test Operation
- HIPPS /ESD Valve Control



## Key Features

- Can be integrated with PLC/RTU/SCADA
- Hydraulic Fusible Plug Loop
- Mostly used in Onshore Environment
- API RP 14C / API RP14B
- Eex 'd', NEMA-4X, IP65 Certified Panels
- NACE MR0175/ ISO-15156 Compliant Panels
- ASME, PED 97/23/EC Design Compliant Components
- Cleanliness Level to any NAS, ISO, SAE Level
- Protective coating for Harsh Environmental Conditions
- High Pressure High Temperature (HPHT) Panels
- Arctic Service Panels
- 3D Model Design Review
- Reliability and Availability Study
- SS316L Tubing Material

## Additional Services

- Installation / Training
- Start-Up Supervision
- Extended warranty
- Customized System

## Single Wellhead Control Panel (Air/Gas Driven)

This Wellhead Control Panel designed to control single wells; It generally comprises of supply reservoir, air/gas driven hydraulic pumps, accumulators, pressure regulators, hand pump, filters and associated control and instrumentation for both, the LP(logic) pneumatic supply header and the HP hydraulic supply headers. In this type of WHCP, LOW and HIGH pressure of pipeline are sensed by mechanical Adjustable Pilot Valves.

The panel is designed to withstand pneumatic pressures of up to 150 PSI and hydraulic pressure of up to 15000 PSI. The Hydraulic pressure is generating by air/gas driven pumps. The Pneumatic pressure is supply from Nitrogen rack bottles or instrumented air or gas of pipeline. The complete panel is enclosed in a Stainless Steel enclosure up to 3mm in thickness, which encapsulates instrumentation and tubing.

The Wellhead Control panel is designed for the highest levels of safety.

### WHCPs may have multiple applications, which include, but are not limited to:

- Safe and Sequential Operation of Wellhead Valves (SSSV/SSV)
- Emergency and Fire Shutdown
- Safe Operation of Riser Valves
- Flow Line Pressure Control
- Well Test Operation
- HIPPS /ESD/ Choke Valve Control



These types of Wellhead Control Panels can be solar power operated and would reduce Carbon footprint and also help make operations more cost effective by eliminating the use of external electricity, compressed air and reduced maintenance cost while improving equipment availability.

WHCP is supplied with solar power system which contains 3 main components:

Solar modules, Charge regulator(s) & Battery bank. Solar modules are assembled on a structure & mounted on top of the panel.

Solar module produces DC power and is wired through the charge regulator to charge the battery bank. The two main functions of the charge regulator are to prevent the battery from being overcharged and to eliminate any reverse current flow from the batteries back to the solar modules at night. Charge controller is provided inside the Local Control Panel, in case of low voltage or over voltage. It disconnects batteries from charge circuit and as well from load circuit to protect the solar system.

The battery bank stores the energy produced by the solar array during the day for use at any time of day or night. Batteries come in many sizes and grades.

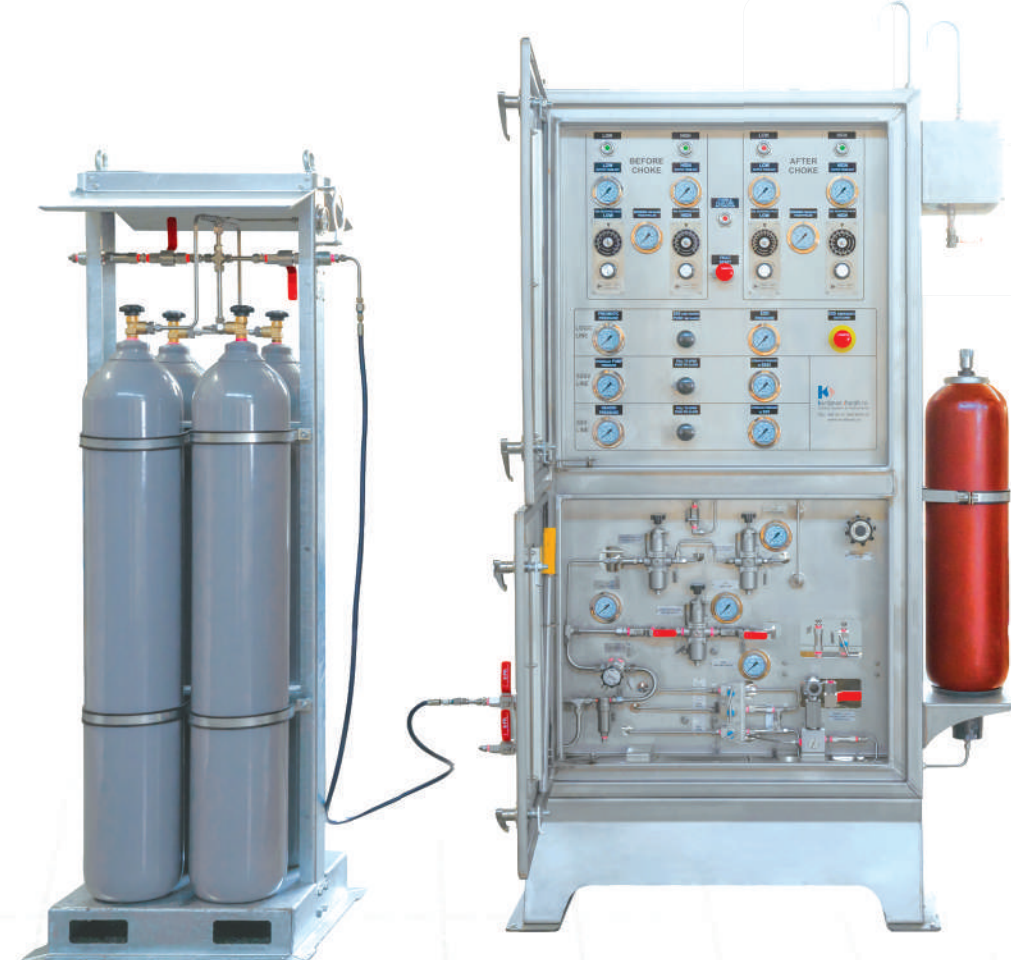

### Key Features

- Can be integrated with Solar Power
- Hydraulic Fusible Plug Loop
- Mostly used in Onshore Environment
- API RP 14C / API RP14B
- IP65 Certified Panel
- NACE MR0175/ ISO-15156 Compliant Panels
- Cleanliness Level to any NAS, ISO, SAE Level
- Protective coating for Harsh Environmental Conditions
- High Pressure High Temperature (HPHT) Panels
- Arctic Service Panels
- 3D Model Design Review
- Reliability and Availability Study
- SS316L Tubing Material

### Additional Services

- Installation / Training
- Start-Up Supervision
- Extended warranty
- Customized System

## Adjustable Pilot Valves

Adjustable Pilot Valve is used in Gas Drive WHCP and also is applicable for places in which there is no electrical power and it is used as mechanical pressure switch.

KARDANAN SHARGH Adjustable Pilot Valves offer accurate, reliable operation to insure years of dependable operation even in the most severe applications. Models are available to sense a wide range of pressures up to 10,000 PSI (690 BAR). Standard pneumatic supply and output pressure is 30 PSI.

## KDAP Model

The KDAP model offers high or low pilot functions in a wide range of pressures. Either high or low sensed limits may be dialed directly into the device. Both high and low pilots are available in a number of ranges from 25 to 10,000 PSI. Supply and output are 30 PSI. This unit is the panel mountable and is usually used in control panels.



## Specifications:

Body Material.....	SS316L
Nominal Pneumatic Supply Pressure .....	30 PSI (2.07 BAR)
Operating Temperature .....	-20° to 80°C
Weight .....	App. 2 kg (KDAP)
Low Set Point Repeatability .....	1.5% Full Scale
High Set Point Repeatability .....	1.5% Full Scale
Hysteresis Dead Band (Trip or Reset) When Output Signal Restored Automatically.....	5%
In compliance with .....	NACE MR0175 / ISO 15156-3(2019) UNS S31603
Dimensions (mm) .....	83 × 190 × 164 (W x H x D) (KDAP)

## Applications

Model KDAP may be used to automatically close a critical valve when line pressure goes outside preset limits high or low. When pressures return to normal, the pilot sends a signal that permits the valve to open.

## KSDA Model

The KSDA model offers high and low pilot functions in a wide range of pressures. Both high and low sensed limits may be dialed directly into the device. Both high and low pilots are available in a number of ranges from 25 to 10,000 PSI. Supply and output are 30 PSI.



## Installation

The Model KDAP must be permanently mounted in the vertical position, and should be mounted in weathertight panel or console to protect it from unusually severe dust, oil, or grit contamination.

## Installation

In KSDA Model, high and low pilots and their respective gauges are mounted on a common box. This model could be not only installed on front panel of GAS DRIVE WHCP, but also it could be installed separately on oil and gas transmission lines as a mechanical pressure switch.

## Installation

In This model could be not only installed on front panel of GAS DRIVE WHCP, but also it could be installed separately as low or high pilot on oil and gas transmission lines as a mechanical pressure switch.

## Linear Scale Type Adjustable Pilot Valve

KARDANAN SHARGH Linear Scale Type Adjustable Pilots offer accurate, reliable operation to insure years of dependable operation even in the most severe applications. Models are available to sense a wide range of pressures up to 680 BAR. Standard Hydraulic/Pneumatic supply and output pressure is 145 PSI.

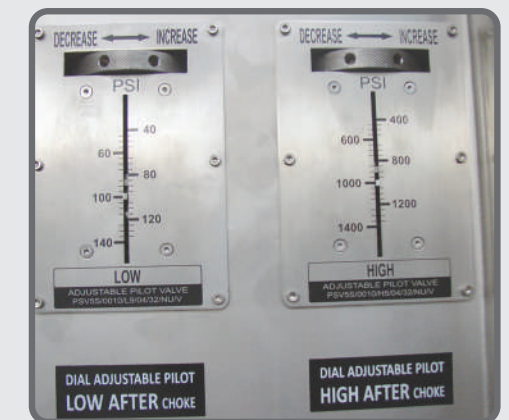
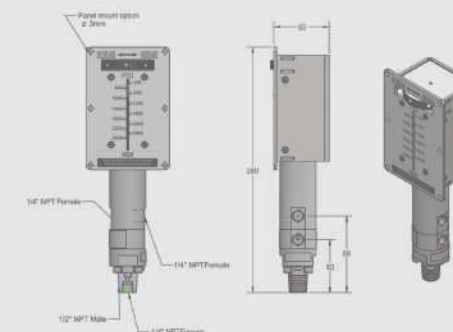



  
kardanan shargh co.  
Control System & Instruments



## PLC Based Wellhead Control Panels

The programmable logic controller panel is designed to meet the client unique process conditions and site-specific requirements to reduce the installation cost by combining high level logic sequence function, PID Control, Shutdown functions, Online fault monitoring, Diagnostic, Alarm & SCADA / RTU functions.

Our PLC panels are designed with best possible System Architecture, application software, programming software, Hardware and Software Configurations as per IEC safety standards and are customized as required by Instrumented Protective System (IPS).

All our PLC based panels are user-friendly in terms of operability, maintainability, availability and reliability.



### WHCPs may have multiple applications, which include, but are not limited to:

- Fail Safe Operation
- IP-55 Certified Panels
- 3D Model Design Review
- Reliability and availability study
- Up to SIL-3 bases on IEC 61508 and IEC 61511
- Panels conforming to relevant IEC standards
- Complete and comprehensive documentation

With Safety Integrated, we can offer first class and uniform solution for the process and production industries and combine these with appropriate services for all life phases of a safety instrumented system which is divided into the analysis, implementation and operation phases.

### Key Features

- Simplex/Redundant configuration in CPU, Power, CP and I/O modules
- Standard designs to ease installation & maintenance.
- Safety modules certified by TUV.
- SCADA interface for remote control.
- Monitoring.

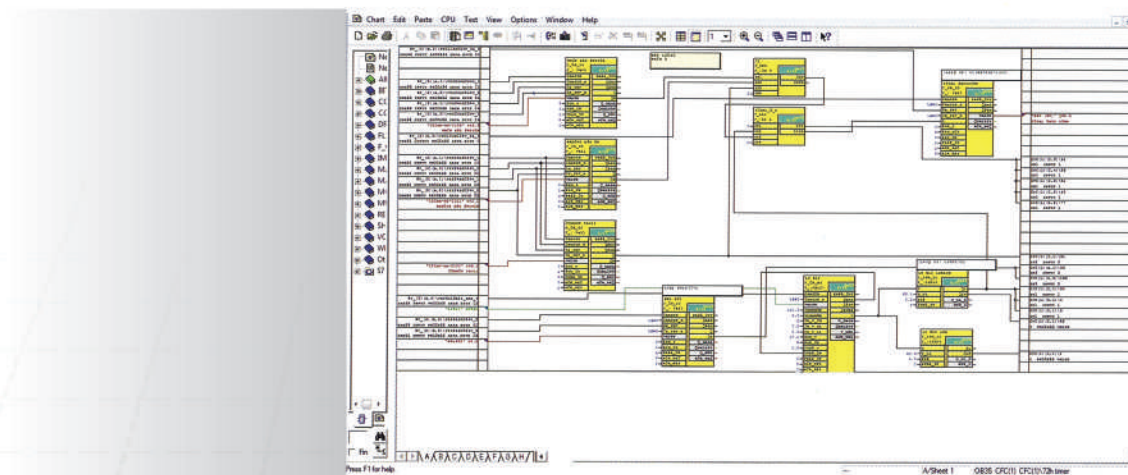
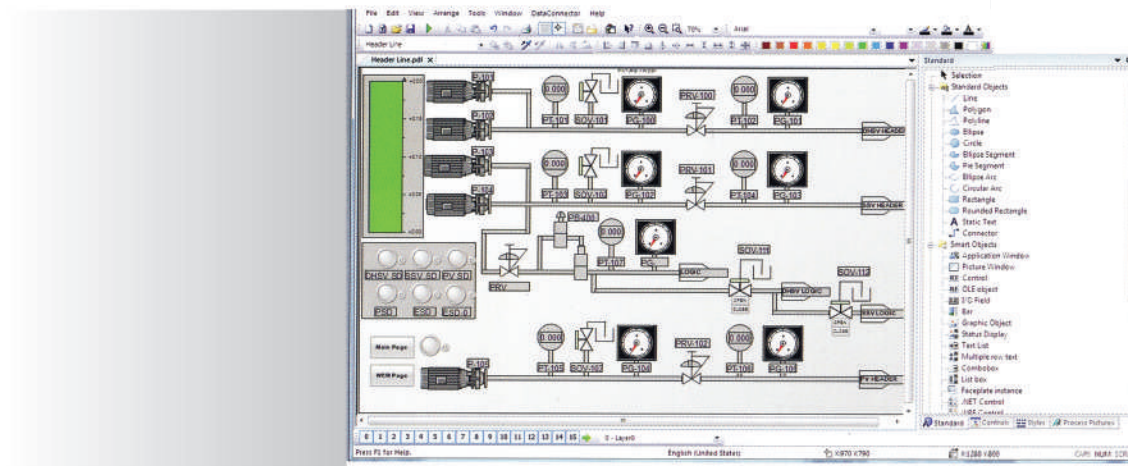

### The following services are available for the PLC panels related to the Safety integrity:

- Configuration and Planning of the Safety Plan
- Safety Requirement Specification (SRS)
- Verification and Validation
- Installation & Commissioning
- Operation and Maintenance
- Documentation

### Additional Services

- Installation / Training Start-Up Supervision
- Extended warranty
- Customized System

## CHEMICAL INJECTION PACKAGE

The Chemical Injection Package serves the purpose of injecting a precise and accurate amount of chemicals into a system with the required back pressure, either continuously or intermittently.

The purpose of injecting the chemicals into a system is to protect the mechanical integrity of the system from accelerated corrosion and prevent scale formation. The aim is also to control hydrate formation, prevent oxygen induced corrosion, emulsion breaker for rapid and sharp separation of water from oil, reduce wax formation, water treatment, Odorization, foam control etc.



### Good reasons to choose a KS Chemical Injection Package

- Compact Design Costs Less than component based site built which reduces overall project cost
- Minimizes overall dimensions for offshore projects
- Design according to customer requirements, application, standard and design codes
- 3-D Modeling of all packages
- Design Validation
- System Performance Guarantee
- Complete system function testing prior to shipment
- Excellent After sale service
- Maintenance and interface hours reduced.

### Standard Features

- Flows from 1 Up To 4000 LPH
- Pressures from 5 Up To 15,000 PSIG
- Heavy Duty API 675 Metering/Dosing Reciprocating Pumps with Packed Plunger Fluid End
- Single/Double Diaphragm Fluid End
- 316 Stainless Steel Materials of Construction

### Industry Standards

- Chemical storage tank meet API650 /API620 / ASME Sec. VIII
- Piping/tubing designed to ANSI B31.1/ANSI B31.3
- Structural Steel Assembly Designed to AWS D1 .1

### Additional Services

- Installation / Training
- Start-Up Supervision
- Extended warranty
- Customized System



### Optional Features

- Remote operation with automatic stroke control of pumps
- Long service life of diaphragm pumps with remote alarm for failure
- High And Low Level Switches
- Skid Drip Pan
- PVC, CPVC Materials Of Construction
- Offshore Paint System
- Chemical storage tank meet UN31A
- Intermediate Bulk Container (IBC)

## Actuator & Control Panel

Scotch-yoke actuators are mechanisms that transform the linear movement of the hydraulic/pneumatic cylinder into a 90° rotation by engaging some internal parts such as sliding block, guide bar and guide block. These actuators are suitable for opening/closing any quarter turn valve.

The driving mechanism of an actuator is a symmetric or a canted scotch yoke which has a parabola torque output curve. This type of torque curve is proved to be the most suitable one for pipeline ball valves. Canted scotch yoke actuators are ideally suited to the larger valve sizes where high break away torques are required or for valves with high working pressure.

One type of actuators is gas-over-oil actuators. In gas-over-oil actuators, the gas flowing in the pipeline is used as a power source. Each actuator is also provided with a connection port to be fed by a separate supply line from a gas storage unit or by bottled gas. The gas-over-oil actuator is engineered and manufactured to work with a pressure supply varying from 7 bar to 105 bar.

The gas-over-oil actuator is fed by pressurized gas which, after being filtered, flows through the control valves into the tank relevant to the operation (opening or closing) to be performed.

The hydraulic oil contained in the tank is pressurized by the gas and flows into the relevant cylinder chamber, while the oil contained in the other chamber flows into the second tank. The cylinder piston stroke causes the actuator operation.

The oil flow from the cylinder into the tanks is adjusted by means of two flow control valves.

In this way it is possible to adjust the stroking time of the actuator.

Emergency manual override can be performed by selecting the opening and closing operation by means of the hand actuated directional control valve and then actuating the hand pump.

This type of actuator can provide up to 300,000 Nm torque which depend on the pipeline pressure and diameter of hydraulic cylinder.

Another type of actuators is single acting spring return actuators. The actuator is made up of a weatherproof scotch yoke mechanism transforming the linear movement of the pneumatic cylinder and of the spring into the rotary movement, which is necessary for operation.

The spring return pack can incorporate up to four springs, fully encapsulated in a factory welded cartridge.

This ensures safety to personnel and simplifies assembly. The spring action can be easily changed in the field from "to close" in "to open" or vice versa (modular design).

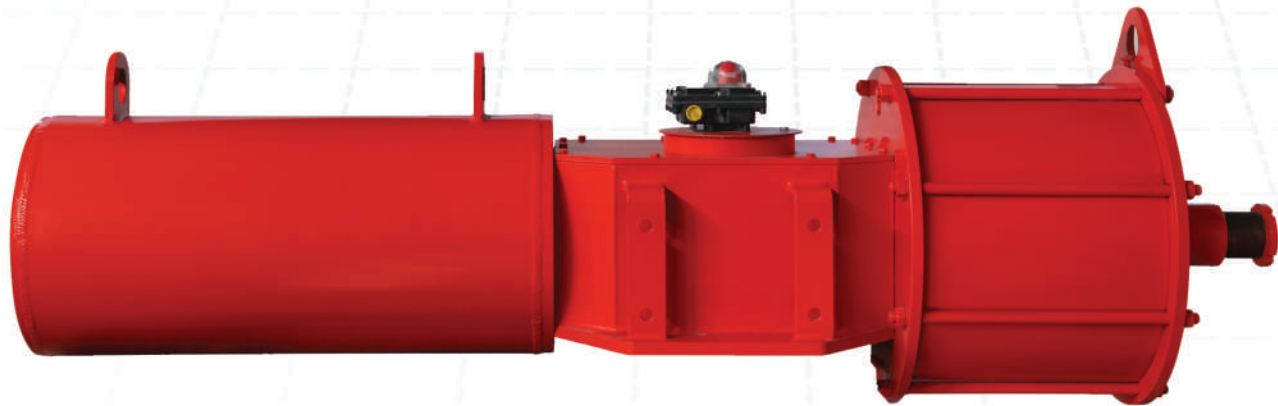

## Line Break Valve (LBV)

Line Break Valve System is specially designed to prevent sudden pressure drops at the oil and natural gas lines in major leak or break.

Line break actuator can be used with all control valves, as local or remote controlled.

It runs using the lines own pressure in Natural Gas Lines.

Line Break Valve system eliminates the extreme pressure changes by measuring the speed of pressure decrease using a device called "DP sensor" or "Line break device."

The actuator will close the valve automatically when the "speed of pressure decrease" is over the adjusted value. When the system automatically performs its Line Breaking function, the 'reset valve' turns itself to the set position and prevents opening the valve.

To re-open the valve, first the line should come back to its normal operating conditions and after making sure of that an authorized person should reset the actuator at the control panel to the initial condition. Line Break Device measures the speed of the pressure change, not the pressure itself.

Let's say while the line is in its normal operating pressure, when a leakage occurs in the line, or a pipe is broken, the system will recognize the pressure loss at the line and secures the line by shutting the valve.

It is preferably set to close in less than 45 seconds for valves smaller than 30 inches in size and less than two minutes for valves larger than 32 inches in size.

The driving mechanism of actuator is a symmetric or a canted scotch yoke which has a parabola torque output curve. This type of torque curve is proved to be the most suitable one for pipeline ball valves.

The Scotch Yoke mechanism is a reciprocating motion mechanism, converting the linear motion of a hydraulic/pneumatic cylinder in to rotary motion of the yokes by engaging some internal parts such as sliding block, guide bar and guide block. The Scotch Yoke actuator produces enough torque to turn a quarter-turn valve in suitable time.

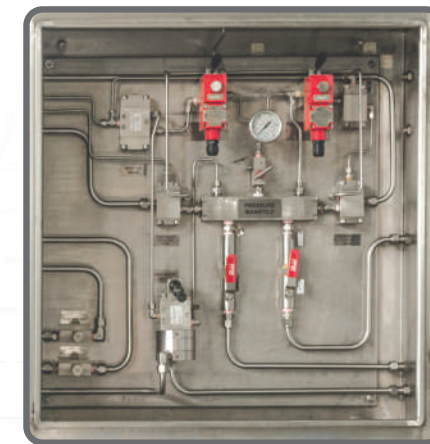

## High-Integrity Pressure Protection System (HIPPS) Emergency Shut Down Valves (ESDV)

When operating in high-pressure environments and production fields, an overpressure event can cause damage to the environment, infrastructure, and personnel. Mitigating that risk on production wells and flowlines is a challenge that can be met with a HIPPS.

A system that closes the source of overpressure within the required timeframe and incorporates redundancy within the initiators (pressure sensors), logic solver, and final elements (shutdown valves) with at least the same reliability as a safety relief valve is usually identified as a HIPPS.

The hydraulic (mechanical) HIPPS provides a self-contained, independent protection system operated on demand with one-out-of-two (1oo2) or two-out-of-three (2oo3) (voting) pressure sensor inputs, a hydraulic logic solver, and two spring-return hydraulically actuated safety valves. The unit is typically self-powered and can be provided with additional real-time controls via a hydraulic power unit (HPU). This pressurizes the system and opens the safety shutdown valves.

The system remains open (armed) until an abnormal condition is detected. If an abnormal condition is detected, then the system closes the two actuated final element valves, protecting the downstream production or facility.

### Applications

- Wellhead flowline
- Pipeline and compressor stations
- Flaring systems
- Separation and processing facilities
- Gas plants
- Gas storage
- Floating production storage and offloading (FPSO) vessels
- Offshore platforms
- Onshore operations

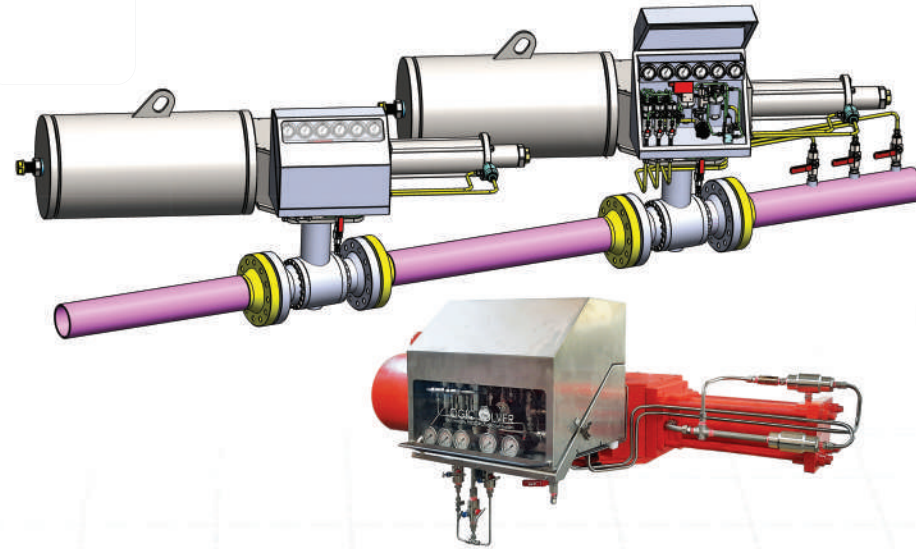

### Key Features & Standards

- High-integrity, flexible mechanical and electronic design
- Pneumatic and hydraulic actuator options (conventional or compact)
- Self-contained hydraulic system
- Partial- or full-stroke testing
- Size 6 inches to 36 inches
- requirements for the specification, design, installation, operation and maintenance of a safety instrumented system (SIS) according to IEC 61511-1: standard
- SIL 3 certified design according to IEC 61508 standard
- Specifies requirements for the attachment of part-turn actuators according to ISO 5211 standard
- Mechanical integrity and sizing of actuators and mounting kits for pipeline valves according to API STD 6DX/ ISO 12490 standard
- Material used in H2S environment according to NACE MR0175 standard



## Hydraulic Power Unit (HPU) & Power Handwheel

Valves are installed at regular intervals alongside the pipelines, which are installed to close or open the path. These valves are sliding type, which are called Gate Valves. These valves are industrial valves that are used to open and close the fluid flow path. Gate valves types are Wedge Gate Valve, Conduit Gate Valve Through, and Knife Gate Valve. The Through Conduit Gate Valve type, which is called pipeline gate transfer valves, is the most in use type. To open these valves manually, a lot of torque is required, and also rotating the wheel by operator is a time and energy consuming activity. Kardanan Shargh company has solved this problem by designing and manufacturing power Handwheel and Portable Hydraulic Unit, which is a mechanical hydraulic equipment, and by creating the right force torque in the shortest possible time.

### Main Components:

#### 1) Power Handwheel:

This equipment consists of several gearboxes and a hydraulic engine. The power handwheel is fixed on the Bevel Gear and has two mechanisms:

a) The first mechanism is manual and the operator can open or close the valve by turning the lever to the manual position and turning the Handwheel. The difference between this mode and the original manual mode (Bevel Gear Operator) is that with the designed gearboxes, the amount of power torque has been reduced by 80%, and this has helped the operator to turn the Handwheel and open or close the valve with much less force.

b) The second mechanism is automatic and uses hydraulic power. The operator can easily use the automatic mode of the device by turning the gear lever to the automatic mode and connecting the hoses of the hydraulic unit to the power Handwheel, which are of the quick coupling type. In this case, it is enough to open the gate valve. Turn on the engine and put the HPU valve in Open mode. It is worth mentioning that with the designed gearboxes, the torque in this case is 97% reduced.

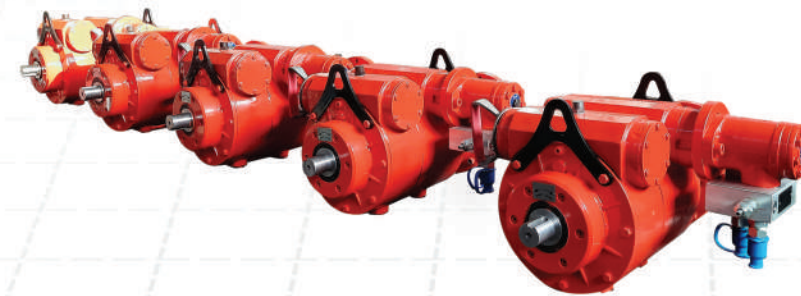

#### 2) Portable HPU:

This device consists of a stainless steel frame and an oil tank. A hydraulic pump driven by a gasoline engine is placed on this frame. The hydraulic pressure created by this pump is transferred to the power Handwheel by flexible hoses with quick coupling. This unit is easily portable by the handle and wheels that are considered for it, and there is no need to prepare it for each valve gate, and one hydraulic unit can be used for several valves.



## Flare & Burn Pit Ignition Panel (Direct Electronic Spark)

KSC has experience of manufacturing direct electric ignition of flare units. A reproducible, high energy, highly reliable spark that is not susceptible to external influences such as moisture and dirt, guarantees the safe ignition and combustion of the residual gas in the flare.

Such direct electric spark ignition may, for example, be used in flares firing coke oven gas and flares where fuel gas containing a minimum of 6% hydrogen is burnt at relatively low flame velocities in the flare head.

In addition, the spark ignition module employed by KSC offers the decisive advantage of thyristor- controlled circuitry that is not subjected to wear and tear. The ignition system is designed to withstand the long operation and maintenance cycles typical for these types of industries.

This equipment is unique because the flare gas is directed to the same ignition zone ensuring ignition regardless of wind speed, wind direction or other environmental factors. The igniter flame is monitored and proven by a data logger or temperature switch, making this Direct Spark Igniter system comply with standards IPS and API 537.

Voltage configurations for the control panels include 220 VAC.

Retractable systems for this equipment are available.

The Direct Spark Igniter is available in straight or bent tip configurations.



## Material Specifications

- Component: SS 316L
- Piping: SS 316L / Carbon Steel
- Head: SS 309 / SS 310
- Pilot gas line: SS 316L
- Exciter line: SS 316L
- Inspirator: SS 316L / Cast Iron
- Fuel: Natural gas, propane, butane

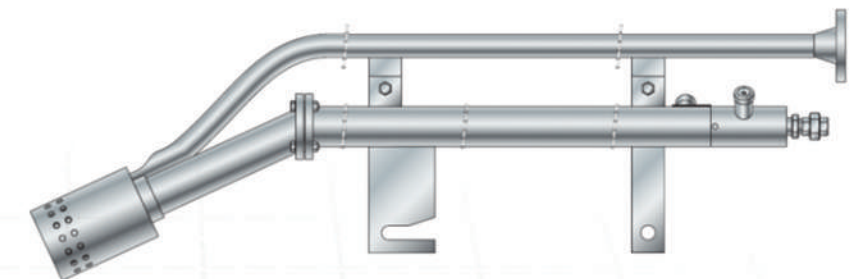

## Advantages

- Rapid Re-ignition response time
- Ease of installation and/or retro-fit applications
- Durability due to high alloy, SS construction
- Temperature indicator switch
- Ignition transformer
- Explosion proof electrical devices
- Flame stability: wind velocities up to 150 mph (240 km/hr)
- Moisture, dirt, oil and grease do not affect the ignition
- No limitation for cable length
- Low power consumption
- Insensitive to process pressure
- Tension is low in comparison to traditional ignition sources

## Applications

- Coke oven flares
- Pipe flares with hydrogen in the waste gas
- Temporary flares from tank farms
- Burn Pit

## Supplier & Agent

Kardanan Shargh Company, with its structured business units, not only manufactures equipment but also supplies goods from reputable countries in Asia, Europe, and America. These products include tubes, fitting, types of pilot valves, process valves, solenoid valves, pressure gauges, hydraulic pumps, gas / air drive pump, metering pump, control box and related electrical equipment, pressure switches, pressure transmitters and other equipment and in general The chain is hydraulic, pneumatic and precision tool.

This company is the only representative of the following brands in Iran:

- HYDR-STAR FLUID CONTROL COMPANY.
- DEPAMU (HANGZHOU) PUMPS TECHNOLOGY Co.
- BAULO SHANGHAY Co.
- CZ ELECTRIC Co.
- SIGMA HLR
- KLEEV

